

NOBEL BIOCARE'S ANALYST CONFERENCE February 11, 2008
Critical Analysis of Statements by Company's CEO, Domenico Scala
by Gerald A. Niznick DMD, MSD. President, Implant Direct LLC.
www.implantdirect.com



QUOTE: Domenico Scala, Feb. 11, Analyst Conference
SUBJECT: TiUnite Advantages

TiUnite is the only biomaterial surface in implant dentistry and is patented by NobelBiocare. It is the only surface that induces bone growth.

FACT: No US Patent for TiUnite or studies proving it is the "only surface that induces bone growth".

Research confirms that rough surfaces on osseointegrated implants improve mechanical interlocking with bone compared to smoother, machined surfaces such as the original Branemark Implant. This has been proven by measuring the amount of torque needed to remove the implant at various times following insertion. While many implant companies claim improved bone attachment with their "new and improved" surfaces, these comparisons relate to their old surfaces rather than to competitors' surfaces. The claim by Scala that "TiUnite is the only biomaterial surface" is wrong. If he meant to say that it is the only bioactive or the only biocompatible surface, he would still be wrong. TiUnite, like all other titanium surface treatments (blasting, etching) forms a layer of Titanium Oxide for bone apposition. Scala's claim that TiUnite "induces bone growth" is questionable. Even if true, again there are no studies that prove the bone response to Tiunite "induces" bone growth any better than any other rough titanium surface available from Nobel's competitors.

The process to create a surface like TiUnite was first developed by a German company called ZL-Microdent-Attachment GmbH & Co KG. Below is a screen-shot from its website at: <http://www.zl-microdent.de/deutsch/dura/dura.htm> They call the surface "TICER" (Titanium Ceramic) and has been used on their ZL-Duraplant Implant since 1992. In the 1980's and 1990's, Nobel claimed that it's machined surface had unique, patented micro-pits contributing to osseointegration. <http://www.implantdirect.com/Pdf/USCourtofAppealsfortheFederalCircuit.pdf> Nobel sued Core-Vent, 3i and a few other companies. A US Federal Court ruled that this surface patent was invalid based on fraud because Nobel and Branemark failed to disclose that pits of claimed (10Nm-1000Nm) were nothing new and could not be avoided in machining titanium.

TiUnite Surface created by passing an electric current through an implant in a electrolytic solution

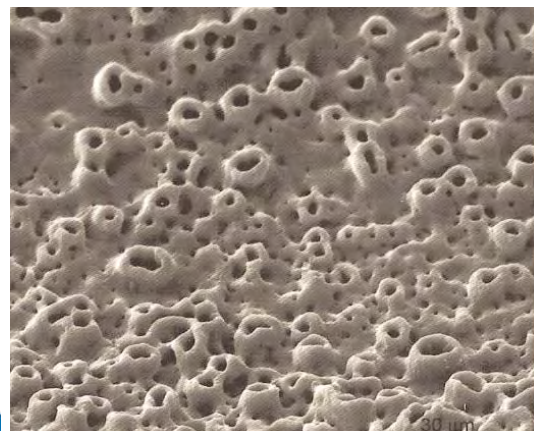

Textured Surface created by use of a Soluble Blast Media of HA Crystals - 15 years of proven clinical success (Implant Direct's SBM)

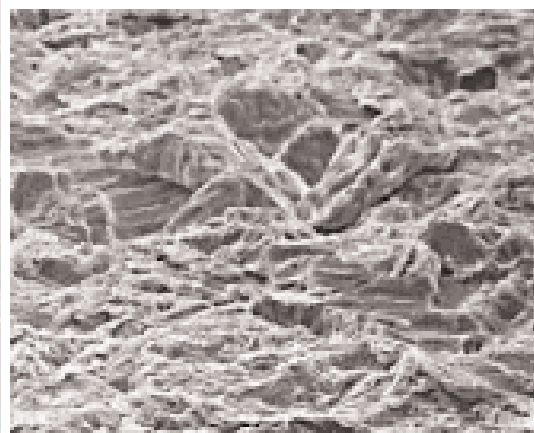

-Startseite Die Planung Oralchirurgie Prothetik Instrumente Zubehör Kontakt / Info

DIE OBERFLÄCHE

Die **TICER®**-Oberflächenkonditionierung erfolgt durch eine anodische Oxidation unter Funkenentladung. Die dabei entstehende rauhe, keramisierte Oberfläche bewirkt bereits nach drei Monaten signifikant höhere Knochenanwachsraten, die durchschnittlich um den Faktor 2 größer sind als bei unbehandeltem Titan Grade 2 (Knöfler, Graf, 1990 / Becker + Mitarbeiter, 1991). Eine spezielle goldfarbene TiO₂-Oberfläche sämtlicher Implantataufbauten gewährleistet eine Minimierung der Plaqueakkumulation im Bereich der Gingivadurchtrittsstelle.

Oberflächenentwicklung in Leipzig

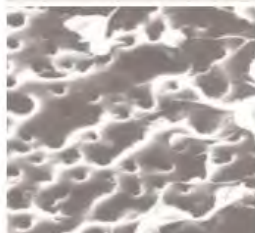

QUOTE: Domenico Scala, Feb. 11, Analyst Conference

SUBJECT: Alpha Bio's Innovation

> **Alpha Bio gives us immediate access to the growth in the orthodontic business through their mini-screws. The mini-implant also will give us access to the fastest growing segment in implant dentistry. The innovative NobelActive thread design can be applied also to mini-implants as we will see from the pipeline slide.**

> **The interesting thing about Alpha Bio is that it comes with enormous innovation capability.**

FACT: Alpha Bio/Fromovich has One US Implant Patent Pending and No Patents issued for Implants or Abutments.

Nobel's CEO cites Alpha Bio's "enormous innovation capabilities". A search of the U.S. patent office web site (www.uspto.gov) under the name Fromovich (President and owner of Alpha Bio) shows only one 2007 patent application for a dental implant (picture to right) and one patent on a surgical instrument. This crude implant design is not directly related to NobelActive or Alpha Bio's existing products. By contrast, a search under Niznick, the President of Implant Direct, lists 25 issued patents plus 8 pending patent applications. One of the issued patents is for the double tri-lobe connection in the RePlant, RePlus and ReActive Implant Direct implants, that offers prosthetic compatibility with Nobel Biocare's existing tri-lobe abutments. Seven of Niznick's pending patent applications are for inventions incorporated in implant products currently sold by Implant Direct. In 1986, Dr Niznick (Core-Vent Corp.) introduced the internal connection to the implant industry with the Screw-Vent Implant. The Screw-Vent, sold today by Zimmer Dental, is one of the most popular and frequently cloned implants in the world. Its internal connection, unchanged in 22 years, incorporates a lead-in 45 degree bevel and a hex wrench-engaging surface in an internally threaded shaft (Niznick Patent #4,960,381 - expired October 2007). Nobel Biocare, the company that claimed for two decades its external hex connection was the "gold standard", has launched the sale of the NobelActive Internal implant with an internal bevel and hex in an internally threaded shaft, claiming it is the "Implant of the Future." This is reminiscent of the movie **"Back to the Future!"** The NobelActive External implant copies the external Morse Taper post design of the 1980's Miter Implant (Driscoll 1985 Patent # 4,547,157). The Miter external Morse Taper post was abandoned by the end of the 1980's and replaced with the internal Morse Taper connection (Bicon, Ankylos) to overcome esthetic and parallelism problems inherent in a 5mm high post that requires a tap-on abutment. **"Those who do not learn from the mistakes of the past are destined to repeat them."**

Scala claims the Alpha Bio acquisition gives Nobel access to orthodontic mini-screws and mini-implants. There is not much design differentiation or market demand for tiny orthodontic screws. Nobel already sells a 1-piece, 3.0mmD mini-implant for \$516, which is \$366 more than Implant Direct's price for its mini-implants, two of which are shown below.

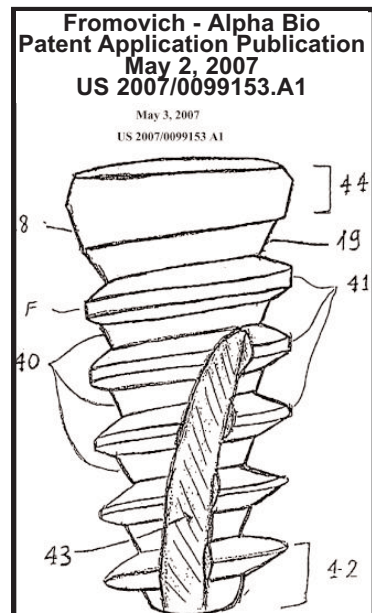

NOBELDIRECT 3.0x13mm
Article Number 31465

493.00 USD

• 3.0
Quantity
1 Add

31417 **Healing Cap 3.0**
Healing Cap 3.0
23.00 USD



Total Cost: \$493 + 23 = \$516

**Alpha Bio
2.4mmD
AAR**



ScrewDirect Packaging



ScrewIndirect Packaging



**Alpha Bio
2.4mmD**



QUOTE: Domenico Scala, Feb. 11, Analyst Conference
SUBJECT: Alpha Bio's
Innovative prosthetic solutions including Angled ball attachments..

Angled Ball Attachment



Alpha Bio's "prosthetic solution" - angled ball attachments are of questionable clinical value.

Scala claimed that Alpha Bio has a pipeline of innovative prosthetic solutions, mentioning specifically "Angled ball attachments". Alpha Bio's catalog shows both straight and angled ball abutments. The use of two free-standing implants to retain a lower overdenture, was first documented in [The Journal of Oral Implantology, Vol.X No.3,1982 by G.A.Niznick](#). Today, most companies make ball abutments for overdenture attachments, including Nobel, Zimmer Dental and Implant Direct and Nobel has a 1-piece implant with a ball attachment head. One of the advantages of using a spherical ball with a snap-on cap to retain a denture, is that any lack of parallelism between the two implants can be corrected by the lab technician. Placing 2 implants relatively parallel to each other is very easily accomplished with guide pins and surgical templates. especially in the front of the edentulous lower jaw where visibility is excellent.

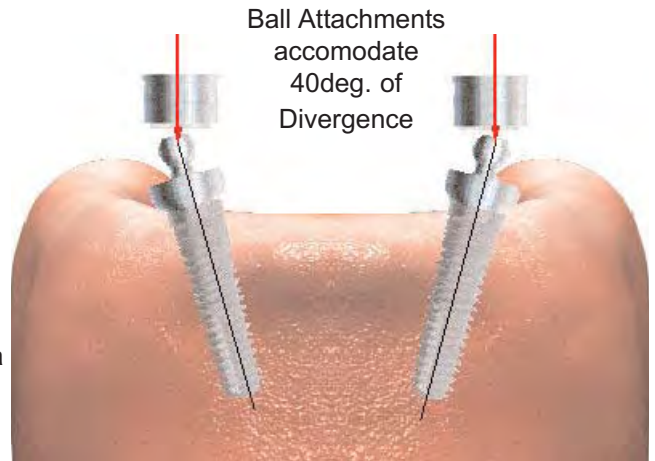

QUOTE: Domenico Scala, Feb. 11, Analyst Conference
SUBJECT: NobelActive Advantages

- > *NobelActive has very unique features - an innovative thread design that expands the treatment options for the clinicians, in particular in situations of soft bone and immediate extractions.*
- > *The design allows the optimum positioning during insertion and provides a unique conical connection for better soft tissue integration.*
- > *Due to its bone condensing features, it will expand the market to indications that can not be treated without grafting procedures today.*
- > *We will continue to capitalize on our innovationsNobelActive is no doubt the most important one.*

CLAIM: "NobelActive... expands the treatment options ...in situations of soft bone."

FACT: The type of spiral, progressively deepening threads on the NobelActive have been available for decades as evidenced by the Pitt-Easy implant, introduced in 1987 by Oraltronics in Germany, and sold today by Sybron (formerly Innova) Implant Company. Such threads on a tapered design, cut into bone rather than expand bone as seen on the comparison picture on the right. The surgical protocol for expanding and compressing soft bone, using a straight undersized drill for insertion of a tapered implant, was first documented in an article in [The Canadian Journal of Oral Health, August 2000, entitled Achieving Osseointegration in Soft Bone - The Search for Improved Results: G. A. Niznick](#). This study related to the Tapered Screw-Vent implant, developed by Dr. Niznick.
[http://www.implantdirect.com/pdf/SoftBoneArticle\(3\).pdf](http://www.implantdirect.com/pdf/SoftBoneArticle(3).pdf)

This same implant and drill design concept and related surgical protocol has been incorporated into Implant Direct's products. Nobel's website describes the Mk IV Branemark Implant as being "slightly tapered and is recommended for use in predominantly soft bone." The Mark IV, Screw-Vent and all of Implant Direct's implants with the exception of its RePlant that is inserted using Nobel Replace's length-specific, surgical drills. The ScrewPlant has a consistent depth of the standard "V" threads over the length of the implant body (blue arrows) starting just below the mini-threads. As the implant is inserted into an undersized socket in soft bone, the shallow depth of the threads compress and expand the soft bone for increased initial stability, in contrast to NobelActive with its progressively deeper threads that creates space for the soft bone to occupy (red arrows).

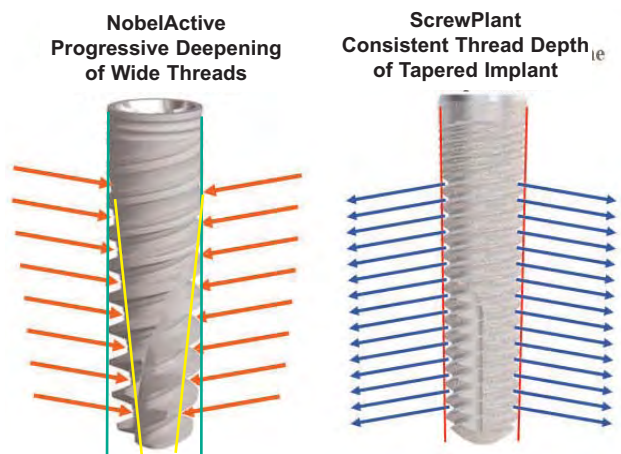

CLAIM: NobelActive “expands the treatment options ... in immediate extraction.”

FACT: The picture to the right shows 5 implants overlaying the same white, tapered trapezoid, simulating an extraction socket. Nobel Biocare’s leading selling implant, the Tapered Groovy Replace™, has its widest diameter at the top as does all of Implant Direct Implants (#1 - RePlant™ implant that duplicates the dimensions and body shape of the Nobel Replace).

The NobelActive™ implants (#2 & #3), taper inward at the top, creating a space for down growth of soft tissue. When the abutment is seated, as shown here, there is a deep undercut that could trap cement. Nobel claims that in soft bone, by preparing an undersized socket, the cortical bone will “rebound,” closing over the top thread. Nobel does not suggest that this can happen in

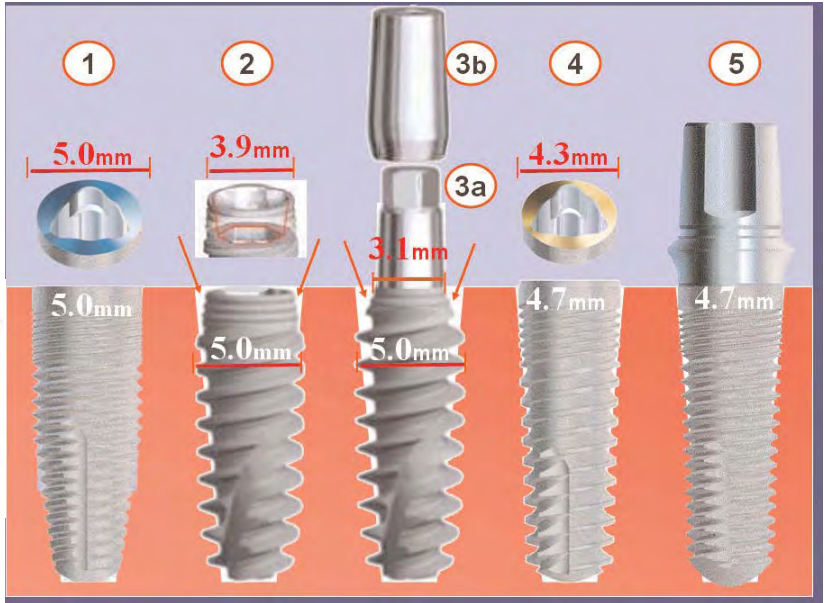

dense bone where, for example, the recommended final drill to insert the 5.0 NobelActive implant is the 4.6mmD step drill, like those reported by Niznick in the 2000 Oral Health published article for a hard bone/soft bone protocol. Similarly, in immediate extraction sockets, the space often remaining around the top of an implant will be exaggerated by the NobelActive’s coronally tapered neck. Both RePlant™ and Replace™ Implants offer a better solution for immediate extraction sites than the NobelActive Internal (#2) and the NobelActive External (#3) implants because they fail to seal the crestal opening to the socket, necessitating bone grafting.

The NobelActive thread design differs from the Nobel Replace and Branemark threads in that they progressively become deeper towards the apex of the implant. The pitch (distance between threads) must be increased to accommodate NobelActive’s very deep threads. The result is that the a NobelActive implant has about half as many threads as the RePlant or Replace implants for the same length. This increased depth creates a space between each thread for the soft bone to passively fit into as the implant is being seated, rather than provide compression for increased stability. This space also allows the end of the implant to wander or be re-directed during insertion. Once the position and trajectory for the implant placement has been carefully established using a sequence of drills or image guided surgery, the socket is suppose to guide the implant to its pre-planned angulation and depth.

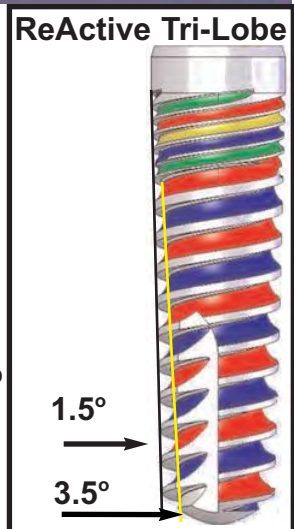

Implant Direct’s ReActive™ implant (#4 and colored thread picture to right) has more aggressive (deep) threads than its other implants. This slightly greater depth apically will increase surface area, thread engagement and stabilization because the inside thread dimension is greater than the recommended drill for soft bone, providing compression and expansion of the bone on insertion.

CLAIM: The design allows the optimum positioning during insertion

Implant #3a is the NobelActive External with its 5mm high tapered post including an external hex for insertion. This is not a one-piece implant because it requires the friction-fit tap-on abutment, #3b, to complete the implant.

This is in contrast to one-piece implants like NobelDirect and Implant Direct’s ScrewDirect™ (#5) that has an integral abutment as part of the implant design. The height of the NobelActive External Implant post, as with one-piece implants, requires placement of the implant in a more vertical trajectory to avoid esthetic problems. If one is going to use an implant with a straight head, requiring a more vertical trajectory, it might as well be a one-piece implant like Implant Direct’s ScrewDirect™ and eliminate the need to purchase an abutment as with NobelActive Internal and External Implants. Nobel claims that one of the NobelActive’s key advantages is the ability to twist the implant to an upright position during insertion. This can be done with any threaded implant in soft bone, but is completely contrary to accepted implant insertion protocols. Implants are placed using a sequence of drills to establish the desired position and angle of the implant in the early stage of insertion. Progressing from smaller to wider diameter drills, and checking the direction with guide pins as the early steps, allows for proper alignment of the surgical site with no change in direction during implant insertion that could cause the implant to become unstable as it threads into the bone. Image guided surgery systems, such as NobelGuide, are predicated on accurate preparation of the implant sockets, without any change in trajectory during insertion of the implant.



• Continue inserting the implant to final position, while gradually changing the angulation.

QUOTE: Domenico Scala, Feb. 11, Analyst Conference

SUBJECT: Alpha Bio Quality of Products

> *As part of the due diligence, we have sent a team to review the manufacturing. The manufacturing is state-of-the-art; high quality standards. May not be all completely efficient because they have 100% manual inspection of their finished products. Just to say however that every single product gets quality controled. So we have*

NOBEL BIOCARE'S EXECUTIVES CLAIM THAT ALPHA BIO HAS HIGH QUALITY:

Alpha Bio has a long history of making poor quality products as evident from the pictures on the right. The top picture shows Alpha Bio's implants and abutments with burrs, pitted surface and ill-fitting parts. The bottom picture shows Alpha Bio parts in 2006, with ill-fitting margins in contrast to Implant Direct's ScrewPlant implant that fits so precisely, the junction between the abutment and implant (where the blasted gray surface meets the shiny machined surface,) is not even visible at these magnified pictures.

Scala stated that Nobel sent a team to review Alpha Bio's manufacturing facility in Israel and found it to be "state-of-the-art, capable of producing high quality products and claims quality is not an issue with Alpha Bio. It is well known in the Israeli implant industry, that Alpha Bio has a number of its implant components manufactured in East Bloc countries for such low prices that even on small sales volume, Alpha Bio was able to enjoy an EBIT margin that, according to Scala, is much higher than Nobel's 33%. Whether Nobel conducted a serious audit of Alpha Bio's product tolerances and QA procedures, especially on outsource products, remains to be known. Perhaps it just looked at some shiny new machines and saw that every part there was being individually inspected for burrs, which is standard manufacturing procedures. procedure with machined parts.

NOBEL CLAIMS ALPHA BIO CAPACITY WILL DELAY BY 2-3 YEARS, NOBEL'S NEED FOR NEW FACTORY

Although Alpha Bio may have added or expanded its manufacturing capabilities in the last couple of years, it is most likely that Alpha Bio is still purchasing abutments and surgical components from low priced machine shops. As shown above, when a company gets implants made one place and the abutments another, the fit between the mating parts is less than ideal. If Alpha Bio's business is expanding, and it has to rely on outsourcing to make some of its products, it is questionable that it will have any open capacity to manufacture parts for Nobel Biocare.

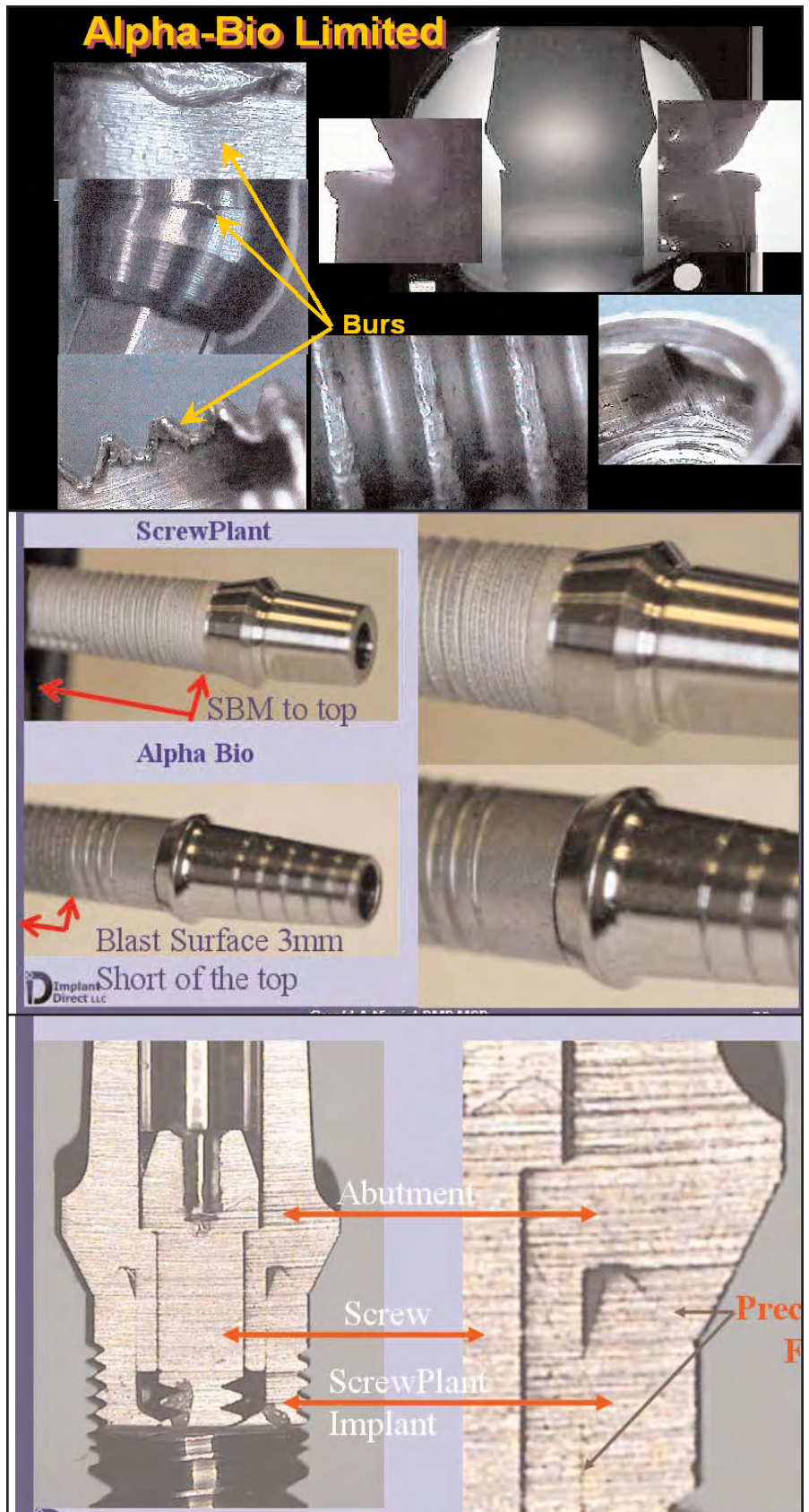

QUOTE: Domenico Scala, Feb. 11, Analyst Conference

SUBJECT: Low Cost Implant Companies

> The low cost or low priced producers which are in the market, they all get a very quick ramp-up - 10, 15, 20 and if you get to Lifecore, 40 million. Their business model stalls to gain scale. They bring no innovation to the plate. They bring no support functions, no training and education. And ultimately this is not a price sensitive market. Our product cost to the final treatment is maybe 10 to 20 percent.

IMPLANT DIRECT SETS A NEW STANDARD IN PRECISION FIT FOR THE INDUSTRY

A cross-section of an ScrewPlant Abutment on the external bevel, internal hex ScrewPlant implant reveals a level of precision unsurpassed by any implant company. Implant Direct had 2 years to perfect its manufacturing processes before selling its first implant in October 2006. It developed the industry's only "lights-out" 24/6 manufacturing capability, with tolerances of $\pm 0.0005"$ (5 ten-thousand of an inch).

Oraltronics' Pitt-Easy Internal Hex Implant On Market since 1987
United States Patent Niznick
 Patent Number: 4,960,381
 Date of Patent: Oct. 2, 1990

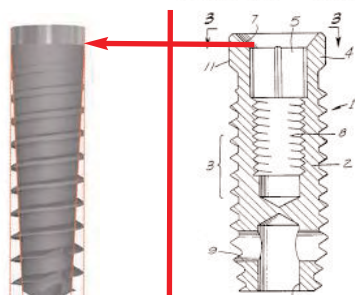

Alpha Bio Tec, an Israeli company started by Dr. Fromovich in 1988, built its business selling low priced clones of Core-Vent Corporation's (Niznick Company started in 1982) Screw-Vent internal hex implant. As evidenced by Alpha Bio's product line below from its current catalog showing clones of the Branemark, Straumann, Pitt-Easy and Imtek products, Alpha Bio is known more for its low prices than for innovation. Alpha Bio's SFB implant design (lower left implant in row) has been incorporated into the NobelActive Implant design with only a few differences. Both SFB and NobelActive implants taper coronally from its widest cross-section diameter about 4mm below the top of the implant. This design, while innovative, is a deviation from generally accepted principals of implant design with the widest cross-section at the top of the implant. This has become the standard of implant design not only because it is logical but also because it has been tried before and it failed. Straumann's Hollow Basket one-piece implants of the 1980's had a narrower neck than the diameter of

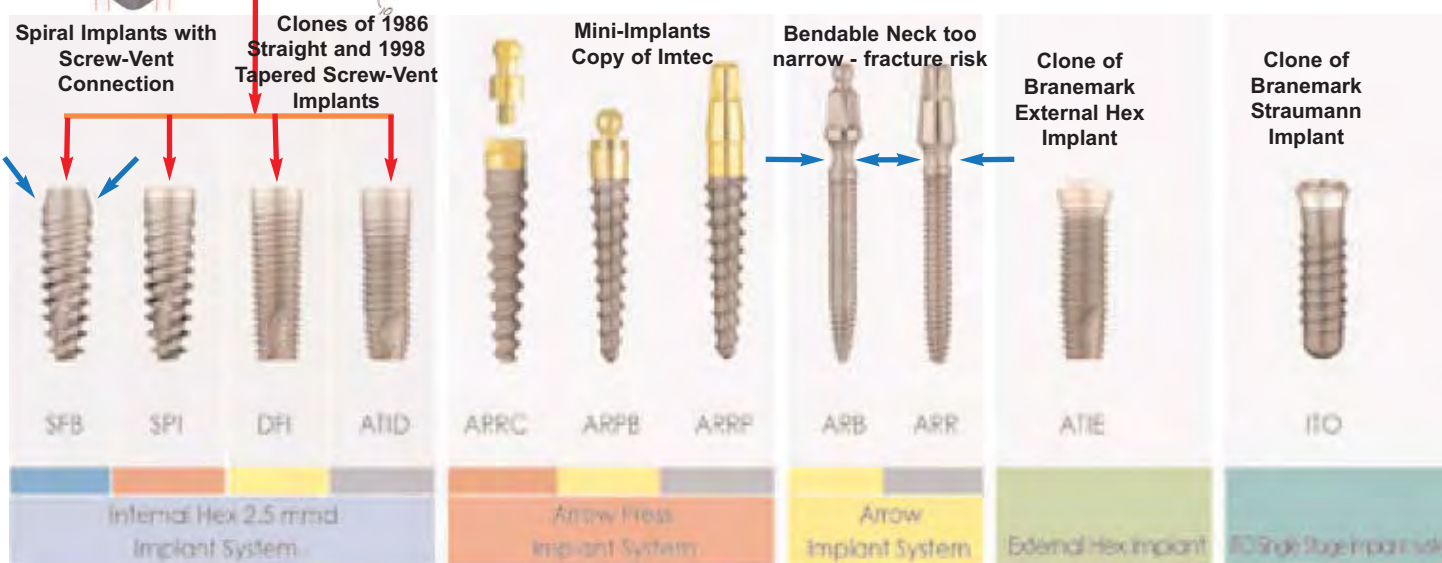

Alpha Bio's success to a great extent has been due to undercutting the prices of other inexpensive Israeli implants to capture that segment of the market that primarily focuses on price. It was able to do so by making much of its products in East Bloc countries for low prices. Concern for quality and precision apparently were secondary as evidenced by the product pictures on the previous page. Scala's statement that low cost implant companies "**bring no innovation to the plate**" **is a direct contradiction** to his statement that Alpha Bio (a small company) has "**enormous innovation capability**" and "**innovative prosthetic solutions.**" Scala describes the NobelActive as having "very unique features (including) a innovative thread design (and) a unique conical connection." In fact, the spiral type of threads with a greater taper to the inside thread diameter than the outside thread diameter, has been around for 3-4 decades. Oraltronics of Germany added an internal hex to a design of a spiral implant in 1987 (Pitt-Easy Implant), which today is sold by Innova.

Alpha Bio's 2.5mmD internal hex connection, shown above, also has Screw-Vent's 45 degree internal bevel, but because of inconsistent tolerances, Implant Direct does not advice using its Screw-Vent and MIS implant compatible abutments with Alpha Bio's implants. The NobelActive internal hex implant does have a 89 degree bevel instead of the 45 degrees of the Screw-Vent, in an attempt to copy Astra's conical connection, but this change has a negative effect of dropping the internal hex further into the implant body, preventing the NobelActive from offering an 8mm long implant. The "innovation" of NobelActive's External implant, with its 5mm high Morse Taper connection, is a copy of the Driscoll's 1985 Miter implant that was abandoned within a few years because the high straight post complicated good esthetics and the establishing parallelism between splinted implants. Alpha Bio's core business is in Israel where it has about 60% of the market. This has been accomplished by selling its implants for about \$60 and abutments for about \$30 to insurance providers.



1. CLAIMS OF NO INNOVATION FROM LOW PRICED COMPANIES:

Nobel said they have 100 R&D personnel and yet its NobelDirect and NobelPerfect implants were developed by practicing dentists. Nobel came under a two year investigation by the Swedish Department of Health because of reports by Gothenburg University of excessive bone loss. Now Nobel purchased Alpha Bio from Dr. Fromovich for \$95M, claiming that it did so primarily to obtain its pipeline of innovation. Generally, Scala is correct about lack of meaningful innovation from small companies but that seems to also be the trend for large companies like Nobel Biocare. Apparently, innovation is more dependent on the person doing the innovating than the size of the company or the price charged for the implants. Dr. Niznick, President of Implant Direct and its sole shareholder has a history of 25 issued US patents with 7 more published applications pending. The features contained in the patents Dr. Niznick has filed since 2004 are incorporated into Implant Direct's broad product line along with his 4,960,381 internal connection patent that expired after 17 years on October 2007. The '381 patent is considered the cornerstone of modern implant design, having been licensed to Straumann, 3i, Friadent, Calcitek (now Zimmer Dental), BioHorizons and copied by many others including Alpha Bio. View Slide Series Critical of NobelActive implants:

[http://www.implantdirect.com/pdf/NobelActive%20Internal%20and%20External%20\(PPTminimizer\).ppt](http://www.implantdirect.com/pdf/NobelActive%20Internal%20and%20External%20(PPTminimizer).ppt)

2. CLAIMS OF NO TECHNICAL SUPPORT FROM LOW PRICED COMPANIES:

Implant Direct currently has 16 customer service and technical support people in the US and 3 in Canada. The US was recently expanded to accommodate a total of 34 within the next 3 months (new facilities shown in December Newsletter). In addition Implant Direct has 6 salespeople in the field, three of which were dental technicians. Implant Direct utilizes the latest online technology to provide on-demand customer support, education and ordering using what is unquestionably the implant industry's most intuitive shopping cart system. Dr. Niznick posts his personal email address right on the home page of Implant Direct's website at www.implantdirect.com. Here is the link to view all the videos in the customer support section of the website, http://www.implantdirect.com/us/customer_support.asp.

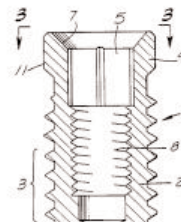
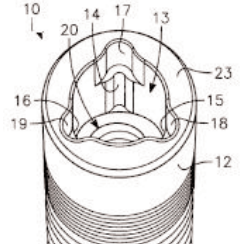
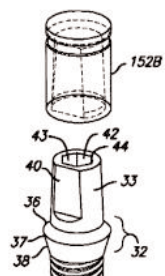
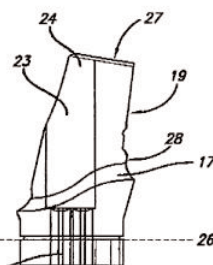
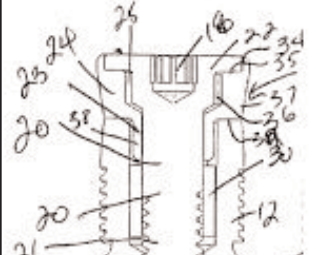
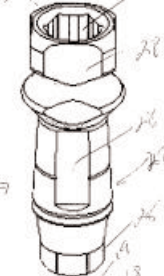
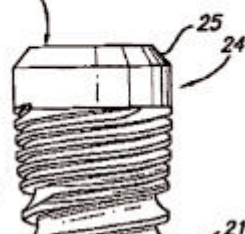
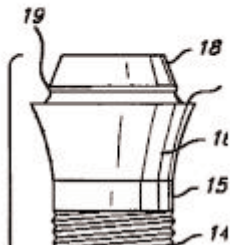
Legacy Implant	RePlant/RePlus Implant	ScrewDirect Implant	ScrewRedirect Implant
<p>United States Patent Niznick Patent Number: 4,960,381 Date of Patent: Oct. 2, 1990</p> 	<p>United States Patent Niznick Patent No.: US 7,108,510 B2 Date of Patent: Sep. 19, 2006</p> 	<p>Patent Application Publication Jan. 5, 2006 US 2006/0003290 A1</p> 	<p>Patent Application Publication Sep. 7, 2006 Sheet 2 of 5 US 2006/0199150 A1</p> 
Healing Collar Extender	Fixture-Mount Abutment	Micro & Double Threads	ScrewIndirect Implant
<p>Patent Application Publication Sep. 7, 2006 US 2006/0199149 A1</p> 	<p>Patent Application Publication Aug. 3, 2006 US 2006/0172257 A1</p> 	<p>Patent Application Publication Aug. 3, 2006 US 2006/0172258 A1</p> 	<p>Patent Application Publication Aug. 17, 2006 US 2006/0183078 A1</p> 

3. CLAIMS OF NO TRAINING FROM LOW PRICED COMPANIES:

Scala misses the point. Implant Direct is targeting “low hanging fruit”, namely experienced dentists who do the bulk of the dental implant surgeries and restorative procedures. Nobel Biocare is training Implant Direct’s future customers for its RePlant Implants as they offer surgical and prosthetic compatibility with Nobel’s leading selling brand the Replace Tapered Groovy implant. Implant Direct also sells the Legacy line of implants and abutments with both surgical and prosthetic compatibility to Zimmer Dental’s Tapered Screw-Vent Implant, developed by Dr. Niznick in 1998. By the second half of 2008, Implant will launch its new line of SwissPlant Implants and abutments for those Straumann customers who want an improved thread design and more esthetic abutments at a third the cost of Straumann..

4. NOBEL CLAIMS THAT LOW PRICED COMPANIES HIT A CEILING OF GROWTH:













While this has been correct, Implant Direct represents a real price-point shift in the implant industry because it combines low prices with a high quality, innovation and a broad product line. Its President and Founder, Gerald Niznick, DMD, MSD, has a 26 year history in the Implant Industry and developed most of the current Zimmer Dental product line before his company, Paragon, was acquired by Zimmer Dental’s predecessor, Sulzer Medical. In just 15 months, 13,000 customer accounts have been established at Implant Direct, with 1000+ dentists receiving RePlant or RePlus tri-lobe Nobel Compatible implants and another 2000 purchasing Nobel compatible prosthetic components. The internet and the public awareness of dental implants are two game-changing events that will allow Implant Direct to continue to grow at the expense of its high priced competitors.

5. THE IMPLANT MARKET IS NOT PRICE SENSITIVE:

Many Dentists will not switch from a higher priced implant just to save money, but will do so if they believe that the product offering is as broad and the quality as good as the one they are using at a high cost. Nobel’s product changes have occurred so rapidly that long-term clinical studies have very little meaning. A number of dentists have become cynical about the credibility of and the need for clinical research. While Scala claims to the Analysts that the industry is not price sensitive, his company gives substantial discounts to high volume customers and new users. Nobel published a price list showing a 40+% discount for dentists taking some courses at NYU. Implant Direct’s low prices for surgically and prosthetically compatible products is providing Nobel customers with negotiating leverage to get significant discounts which is hurting Nobel’s bottom line even if they keep the customer. [A Merrill Lynch Analyst’s Report](#), published February 25, 2008 comments on Nobel’s acquisition of Alpha Bio and the potential risks of selling both a high and low priced implant while claiming equal success. **The comparison pictures below show significant product advantages and huge price difference that can not be ignored, especially in these uncertain economical times.**

**Merrill Lynch Analyst Report. Feb. 25, 2008
AlphaBio Acquisition - We Don’t Like It.**

“We view the acquisition of AlphaBio as defensive, driven by the risk that Nobel’s ‘implant of the future’ (NobelActive) may have had to compete against a +50% ‘cheaper’ alternative, on which material design features are ‘oddly’ based on. We are also concerned that Nobel may have accelerated the ‘creeping’ challenge, of trying to justify the price differential between ‘premium’ and ‘generic’ implants, especially when AlphaBio can show similar implant success rates of +98%”

<p>Implant Direct RePlant \$150 Package Includes Cover Screw & Transfer</p> <p>Surgical and Prosthetic Compatibility with Replace RePlant - TiAlloy for 20% Greater Strength</p>   <p>Mini-Threads</p> <p>Double-Lead Standard V-Threads For 2X Faster Insertion</p> <p>Self-tapping Groove</p> <p>Apical Threads</p>		<p>Nobel Replace Groovy \$452 adding Cover Screw & Transfer</p>  		<p>ScrewDirect™ Implant vs *NobelDirect® Implant</p> <p>ScrewDirect Includes Snap-on Carrier-Transfer & Snap-on Comfort Cap</p>  <p>NobelDirect Posterior: *Price includes Snap-on Cap (\$25) & Transfer (\$25) Nobel Posterior Available in 13 & 16mm ScrewDirect available in 10, 13 and 16mm</p> <p>Prosthetic Limitations of NobelDirect Posterior Retentive Element for Snap-on components is within the Internal Shaft - If the top of the implant is shortened, the Snap-on components can not be used. *NobelDirect is a Registered Trademark of Nobel Biocare</p>							
<p>ScrewDirect Includes Cap Transfer</p>  <p>3.0mmD \$150</p>	<p>NobelDirect No Transfer</p>  <p>3.0mmD *\$516</p>	<p>ScrewDirect Includes Cap Transfer</p>  <p>3.7mmD \$150</p>	<p>NobelDirect Posterior + Cap Transfer</p>  <p>4.3mmD *\$564</p>	<p>ScrewDirect Includes Cap Transfer</p>  <p>4.7mmD \$150</p>	<p>NobelDirect Posterior + Cap Transfer</p>  <p>5.0mmD *\$583</p>	<p>ScrewDirect Includes Cap Transfer</p>  <p>5.7mmD \$150</p>	<p>NobelDirect Posterior + Cap Transfer</p>  <p>6.0mmD *\$583</p>				